

PR387

| | |
|--------------------------|---|
| Design | Pneumatic double-piston rotary actuator in rack and pinion design |
| Function | Double- and single-acting execution |
| Standards | Interface actuator/feedback-unit - VDI/VDE 3845 (NAMUR) Interface actuator/control media - VDI/VDE 3845 (NAMUR) Interface actuator/valve - ISO5211 / DIN 3337 |
| Temperature range | Standard: -20°C ... +80°C Low temperature version: -40°C ... +80°C High temperature version: -10°C ... +150°C |
| Nominal angle | 90° |
| Angle adjustment | Adjustable in both end positions +/-5° Optional stroke adjustment up to 100% |
| ATEX marking |  II 2 G Ex h IIC T6...T3 Gb II 2 D Ex h IIIC 170°C Db |
| Control Pressure | 2 up to 8 bar |
| Control media | dry, filtered air or inert gases in respect of remaining oil-, dust and water-content according to DIN ISO 8573-1 / class 4, maximum particle diameter 30µm, dew point minimum 10°C below ambient temperature |
| Material | Body: Aluminium, powder-coated Caps: Aluminium, powder-coated Pistons: Aluminium Pinion shaft: Carbon steel, nickel plated Bearings: POM Sealings: Standard: NBR Optional: HNBR/FPM/Silicone Screws: Stainless steel |



Torque diagram

Double-acting

Provides a linear and constant torque through the complete pivoting angle in both pivoting directions.

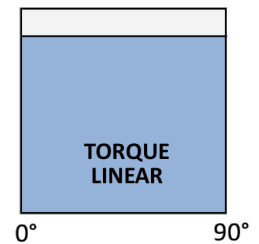

Single-acting

Provides a linearly reducing torque through the complete pivoting angle in both pivoting directions.

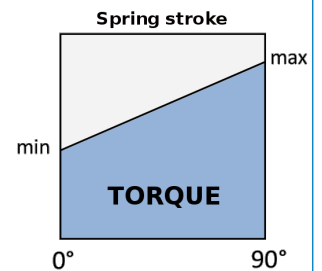

Offers the maximum torque at the beginning of each stroke to overcome the breakaway torque.

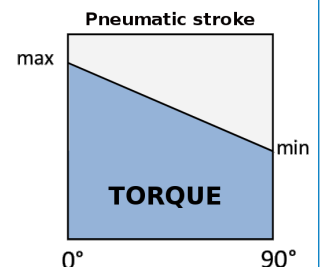

Dimensions

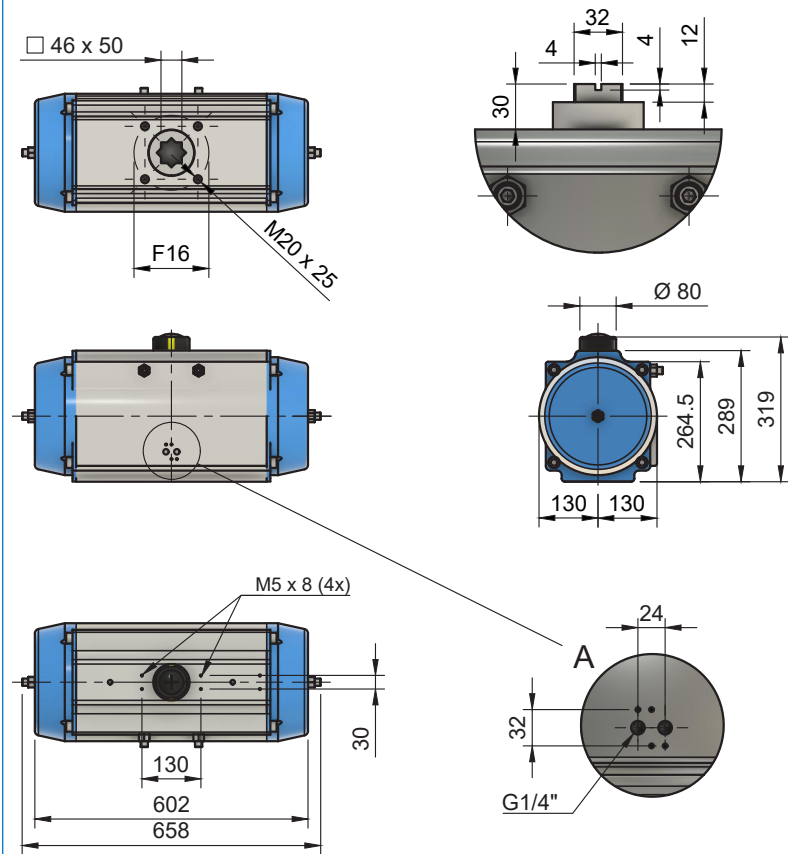

Angle adjustment

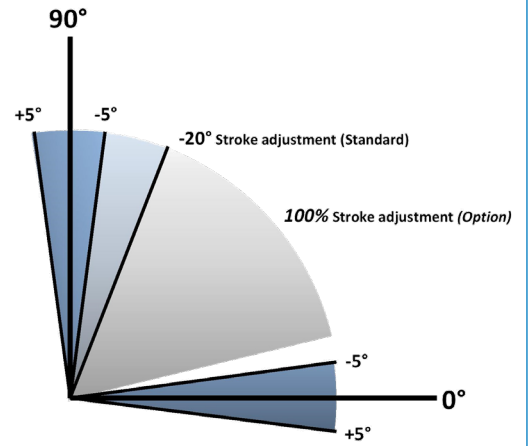

Both end positions can be adjusted by +/-5° for a precise setting of the final valve position.

The optional stroke adjustment offers a 100% setting of the switched end position.

Torques double-acting

| Control pressure in bar (g) | 2 | 2,5 | 3 | 3,5 | 4 | 4,5 | 5 | 5,5 | 6 | 6,5 | 7 | 7,5 | 8 |
|-----------------------------|-----|-----|------|------|------|------|------|------|------|------|------|------|------|
| Torque in Nm | 773 | 966 | 1160 | 1353 | 1547 | 1740 | 1934 | 2127 | 2321 | 2514 | 2708 | 2901 | 3095 |

Torques single-acting

| Torque spring stroke in Nm | | | | Control pressure in bar (g) | | | | | | | | | | | | | | | | | |
|----------------------------|------|-----|-----|-----------------------------|-----|-----|------|-----|------|------|------|------|------|------|------|------|------|------|------|------|--------------|
| | | | | 3 | | 3,5 | | 4 | | 4,5 | | 5 | | 5,5 | | 6 | | 7 | | 8 | |
| Spring set | max | min | max | min | max | min | max | min | max | min | max | min | max | min | max | min | max | min | max | min | |
| | | | | | | | | | | | | | | | | | | | | | Torque in Nm |
| 6 | 665 | 492 | 662 | 489 | 855 | 682 | 1047 | 874 | 1240 | 1067 | 1432 | 1259 | | | | | | | | | |
| 7 | 775 | 575 | 580 | 379 | 772 | 572 | 964 | 764 | 1157 | 957 | 1349 | 1149 | | | | | | | | | |
| 8 | 886 | 656 | 498 | 268 | 691 | 461 | 883 | 653 | 1075 | 845 | 1267 | 1037 | 1460 | 1230 | 1652 | 1422 | 2037 | 1807 | | | |
| 9 | 998 | 739 | | | 608 | 350 | 800 | 542 | 993 | 734 | 1185 | 926 | 1377 | 1119 | 1569 | 1311 | 1954 | 1696 | | | |
| 10 | 1108 | 821 | | | | | 718 | 431 | 911 | 624 | 1103 | 816 | 1296 | 1009 | 1488 | 1201 | 1872 | 1586 | 2257 | 1970 | |
| 11 | 1219 | 903 | | | | | | | 829 | 513 | 1021 | 705 | 1214 | 898 | 1406 | 1090 | 1791 | 1474 | 2176 | 1859 | |
| 12 | 1330 | 985 | | | | | | | | | 939 | 594 | 1131 | 787 | 1323 | 979 | 1708 | 1363 | 2093 | 1748 | |

Weight, volume

| Function | Weight (kg) | Volume (l) |
|---------------|-------------|------------|
| double-acting | 67,0 | 20,0 |
| single-acting | 80,0 | 11,0 |

Air consumption

| Function | Air consumption for pivoting angle 90° at control pressure in bar (g) in litres/cycle | | | | | | | | |
|---------------|---|------|------|------|-------|-------|-------|-------|-------|
| | 3 | 3,5 | 4 | 4,5 | 5 | 5,5 | 6 | 7 | 8 |
| double-acting | 60,0 | 70,0 | 80,0 | 90,0 | 100,0 | 110,0 | 120,0 | 140,0 | 160,0 |
| single-acting | 33,0 | 38,5 | 44,0 | 49,5 | 55,0 | 60,5 | 66,0 | 77,0 | 88,0 |